

ELECTRIC BUILDER'S HOIST



Features

- Lightweight and compact design for convenient mounting
- Dynamic and mechanical brake provides instant and safe braking
- Upper and lower limit switches for additional safety
- Galvanized wire rope with 360-degree weighted hook includes safety latch
- Quick release pendant and power cords
- Operates on standard domestic power supply

Standards - CE

Specs

	OBH500	OBH1000
Lifting Capacity (Full Drum)	500 lbs	1000 lbs
Motor Voltage	115/1/60	115/1/60
Speed	75 fpm	37 fpm
Lifting Height	90 ft	90 ft
Wire Rope	3/16 in	1/4 in
Winch Weight	48 lbs	69 lbs
Gross Weight	54 lbs	73 lbs
Power cord length	15 ft	15 ft
Pendant length	65 ft	65 ft
Full Load AMPS	17.5	15.5
Duty Cycle (min)	15 (25%)	15 (25%)

75 fpm
OBH500

37 fpm
OBH1000



500, 1000 LBS

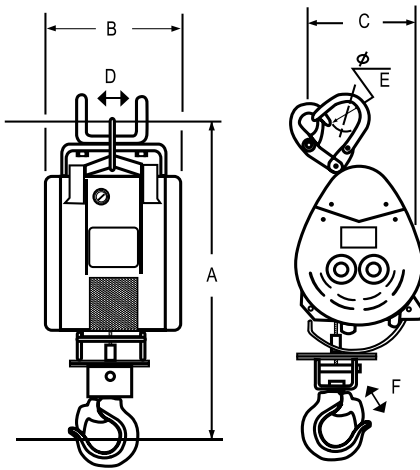

		OBH500	OBH1000
A (in)	Height	26.77	28.50
B (in)	Width	9.50	10.50
C (in)	Depth	7.88	12.00
D (in)	Hanger Width	4.50	4.50
E (in)	Hanger Opening	2	2
F (in)	Hook Opening	1.62	1.50

*Dimensions are for reference only and subject to change without notice.



MOUNTING AND LIFTING SOLUTIONS

Mounting Arm Bracket

- Long last powder coat finish
- Solid mounting bracket
- Portable / Light Weight
- Quick mount
- Made in USA



OBH230	
Width (W)	40 1/2 inches
Height (H)	17 3/4 inches
Mounting Pipe (D)	2 1/8 inches
Capacity	1000 pounds
Net Weight	26 pounds

Pipe Not Included

Pipe Not Included



NEW!



OZ05PBTA-OBH
Trolley with OBH Hanger
Contact us for more information.



NEW!

NEW!

Refer to OZ05PBTA dimensions on page 15



OZ1GBT-OBH
Geared Trolley with OBH Hanger
Contact us for more information.

Refer to OZ1GBT dimensions on page 17

Clamp with OBH Hanger COMING SOON!